

RUBBISH CHUTE TECHNICAL NOTE

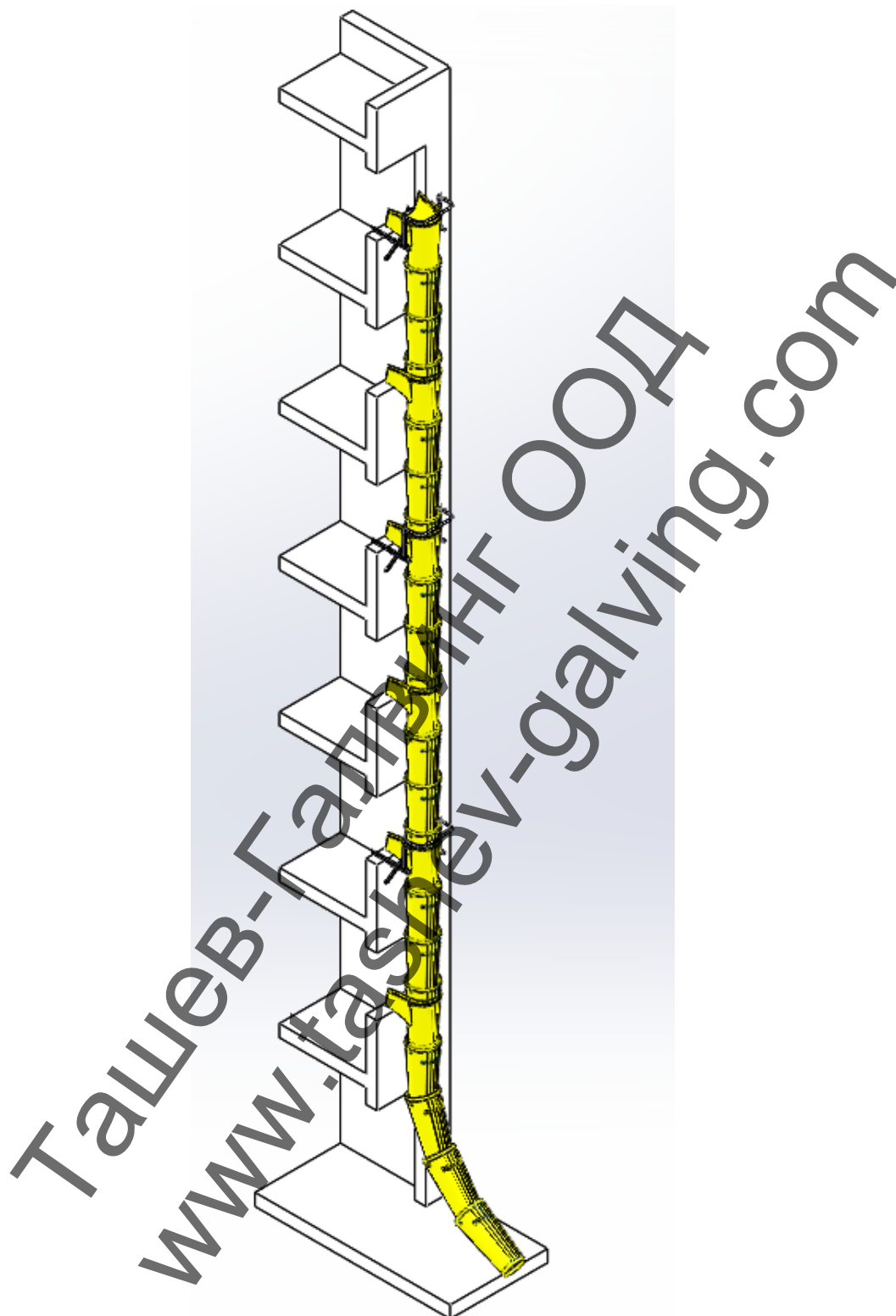

Haemmerlin



HAEMMERLIN - CDH GROUP
28 RUE DE STEINBOURG - BP 30045 - 67701 SAVERNE CEDEX - FRANCE
Tel. + 33 (0)3 88 01 85 00 - Fax + 33 (0)3 88 01 85 39
welcome@haemmerlin.com - www.haemmerlin.com

TECHNICAL NOTE

Instructions for installing and using the rubbish chute and accessories.

The HAEMMERLIN rubbish chute is the result of many years of research and perfecting to improve the quality and safety of the rubbish chute.

We nevertheless recommend respecting the following instructions to ensure you get the most out of the product whilst optimising safety conditions and respect for the environment.

Before installing or using the rubbish chute or any accessories, make sure that all users are fully aware of the instructions in this technical note.

This technical note should be easily accessible to users of the rubbish chute.

HAEMMERLIN disclaims any responsibility for any consequences due to improper use or installation of the rubbish chute and its accessories according to this technical note, as well as any consequences due to dismantling, modification or replacement of any parts with other parts supplied by a third party without written consent.

In the framework of its constant efforts to improve its products, HAEMMERLIN reserves the rights to alter materials at any time.

Description:



Rubbish chute section
Code 318101001



Hopper chute section
Code 318102001



Chute moderator
Code 318107001



Safety clip to ensure secure assembly
(exclusive to Haemmerlin)

Technical specifications for chute and hopper sections:

- Materials: ecological polypropylene copolymer (fully recyclable)
- Breaking strength of chains: 1000 kg/chain (2205 lbs)
- Weight of chute section: 6.7kg (14 lbs)
- Weight of hopper chute section: 8.3kg (18 lbs)
- Total length: 1.10m (43")
- Usable length: 0.85m (31")
- Internal diameter: 507/380mm (20"/11")
- Outside diameter: 515/395mm (20^{1/4}"/15^{1/2}")
- Overall width of chute section: 620mm (24^{1/2}")

Overall dimensions of the hopper chute section: 620 x 740mm (24^{1/2}" x 29")

Feel free to ask us for our complete installation guide for more technical information on rubbish chutes and accessories.

Preparing the worksite:

- Measure the height and distance between the starting point and the finishing point in order to calculate the number of chute sections required. In order to determine the number of chute sections required according to the height of the building, divide the height of the building by the usable length of the rubbish chute sections (0.85m/31"). For example, for a building measuring 40m (130ft) high: $\frac{40}{0.85} = 47$ chute and hopper sections.
- Position the starting point so that users have full visibility of the rubbish chute.
- Depending on the set-up of the worksite, choose the appropriate fixing frame for anchoring the rubbish chute.

WINDOW FIXING FRAME
Code 318103201

SCAFFOLDING FIXING FRAME
Code 318104501

PLATFORM FIXING FRAME
Code 318103501

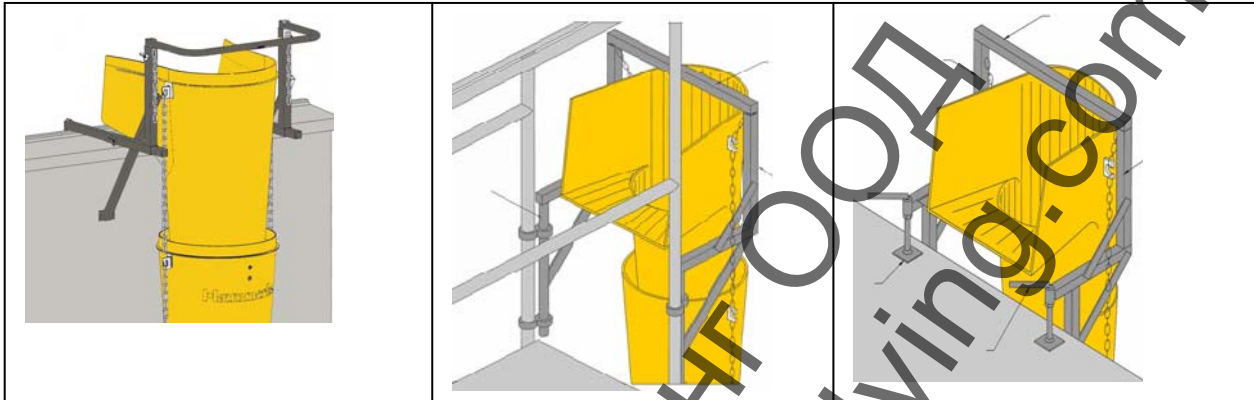

Calculation of the number of rubbish chutes needed

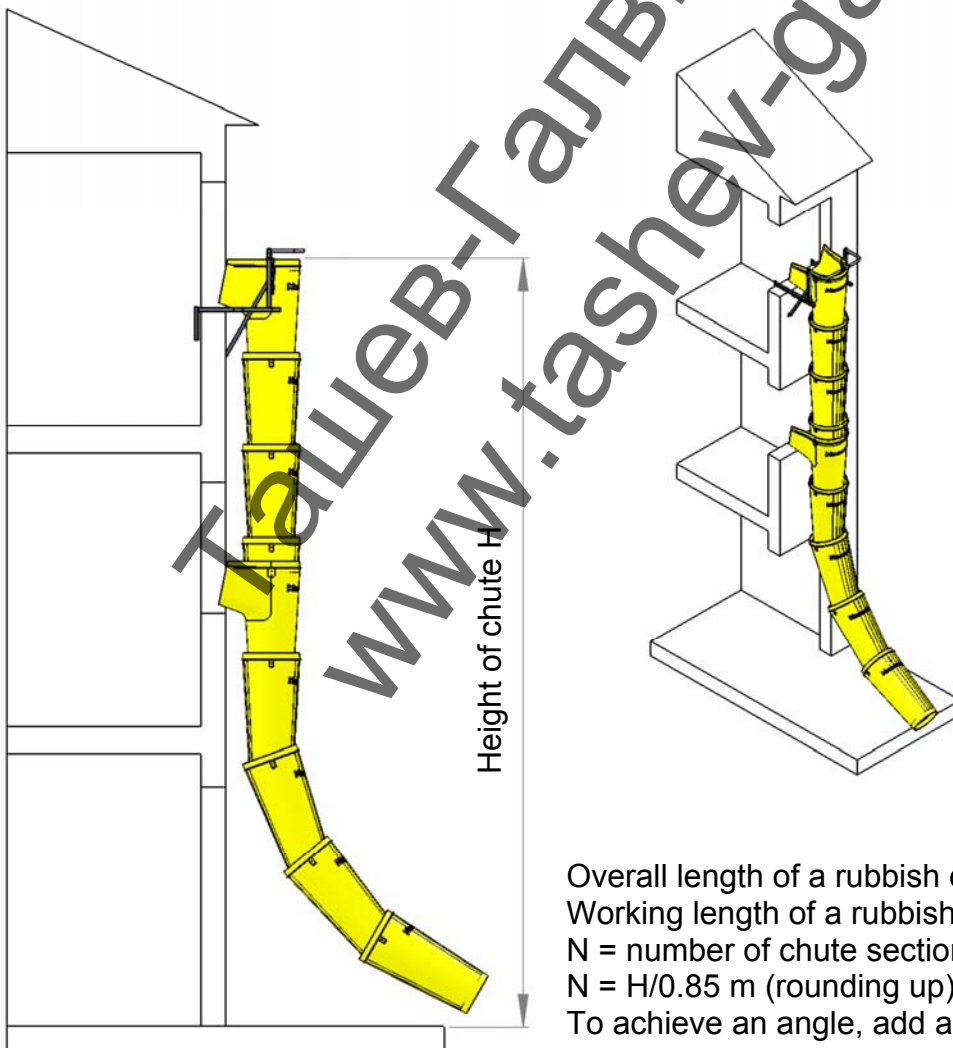

Overall length of a rubbish chute/hopper = 1,10m
Working length of a rubbish chute/hopper = 0,85m
 N = number of chute sections required for a height of chute H
 $N = H/0.85 \text{ m}$ (rounding up)
To achieve an angle, add a supplementary rubbish chute.

Installing the window fixing frame (see diagram):

The window fixing frame is suitable for mounting to window openings, sills, parapets etc. It is mounted to the building using the two strut jacks. It can be mounted to walls of thicknesses between 200 and 400mm (8" and 16"). **A maximum of 10 chute sections can be attached to a window fixing frame, representing a maximum distance of 8.50m (28ft) between two window fixing frames. Moreover, an intermediate point of anchorage to the building is required for the rubbish chute between two fixing frames using a rope or a chain (not supplied).**

It is composed of:

- A > Sleeve (x2)
- B > Strut jack (x 2)
- C > Crosspiece (x1)
- D > Bolt (x4)
- E > Nut (x4)

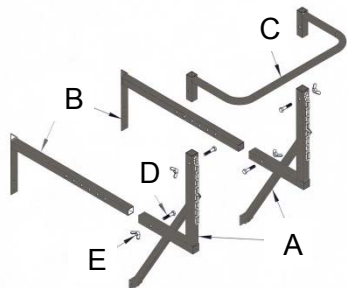

Installation:

- Before installing the window fixing frame for rubbish chute kits, check the strength of the anchor point where it will be fixed (window recess, sill, parapet etc.). Take into account the weight of the chute sections as well as the potential weight of the debris, which may obstruct the rubbish chute in case of improper use.
- Measure the thickness of the wall at the anchor point where the window fixing frame will be installed.
- Insert the strut jacks (B) into the sleeve (A), then adjust the strut jack in the sleeve according to the thickness of the wall previously measured. Lock the strut jack in place in the sleeve using the bolts (D) and nuts (E).

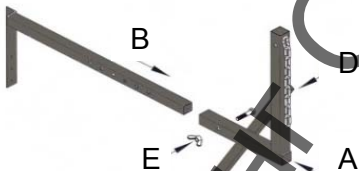

- Repeat the process with the second strut jack and sleeve.
- Fix these two components to the anchor point keeping enough distance between them for receiving the crosspiece (C).
- Slot the crosspiece into place (C) and secure using the bolts (D) and nuts (E).

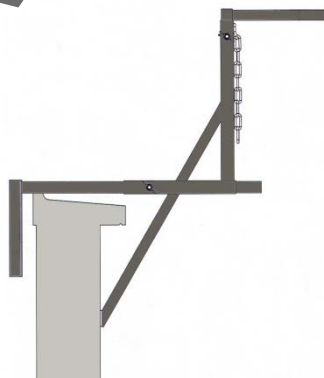
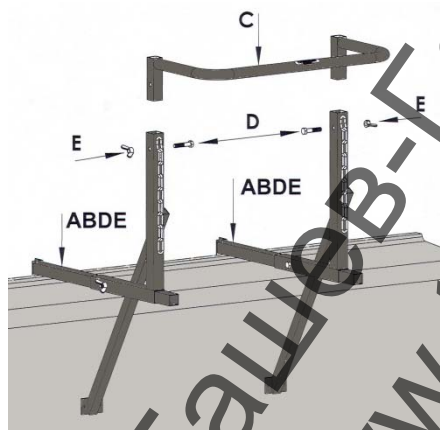

- Insert a plank between the inside of the wall and the supports to make the installation perfectly stable and to ensure proper distribution of the weight load on the wall, sill or parapet.
- The plank must be screwed or nailed securely to the supports of the jacks to prevent it from suddenly coming free.

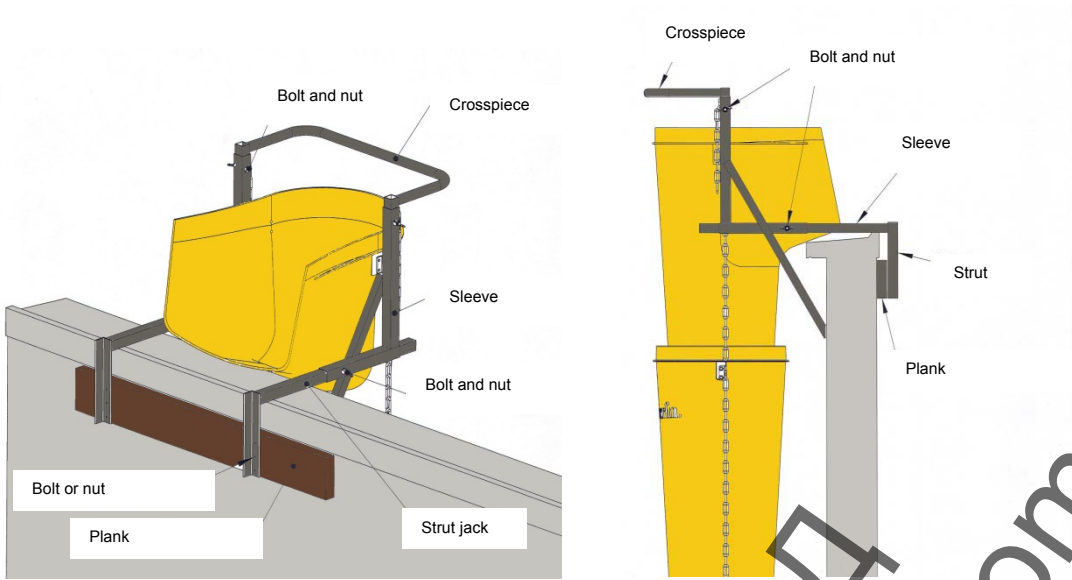

The chute sections can now be mounted to the window fixing frame.

Ташев-Галвинг ООД
www.tashev-galving.com

Installing the scaffolding fixing frame (see diagram):

It is appropriate for scaffolding, metal structures etc.

It can be mounted to a tubular structure or scaffolding using orthogonal couplers or double couplers (D49). The couplers are not supplied with the scaffolding fixing frame.

The maximum number of chute sections which can be attached to a scaffolding fixing frame depends on the height of the worksite:

- For heights up to 40m (131ft), a maximum of 16 chute sections can be attached to a scaffolding fixing frame, representing a maximum distance of 13.6m (45ft) between two scaffolding fixing frames. Moreover, an intermediate point of anchorage to the scaffolding is required between two fixing frames using a rope or a chain (not supplied).
- For heights ranging from 40m to 60m (130ft-196ft), a maximum of 12 chute sections can be attached to a scaffolding fixing frame, representing a maximum distance of 10.20m (34ft) between two scaffolding fixing frames.
- For heights above 60m (196ft), a maximum of 10 chute sections can be attached to a scaffolding fixing frame, representing a maximum distance of 8.50m (28ft) between two scaffolding fixing frames.
- Before installing the fixing frame, check the scaffolding strength is sufficient and that it is securely anchored to the building. Take into account the weight of the chute sections as well as the potential weight of the debris, which may obstruct the rubbish chute in case of improper use.
- The fixing frame can be mounted directly to the stiles of scaffolding ladders or to specifically-assembled scaffolding poles using couplers.
- Install the left side by mounting the frame's lower upright to the scaffolding pole using two double couplers (not supplied). Do not tighten the couplers completely.
- Repeat the procedure for the right side of the frame.
- Use the upper crosspiece to adjust the level and distance between the left and right sides. Slot the crosspiece onto the upper uprights on either side of the frame.
- To secure the installation, tighten the four couplers until the fixing frame is perfectly stable and secured to the scaffolding.

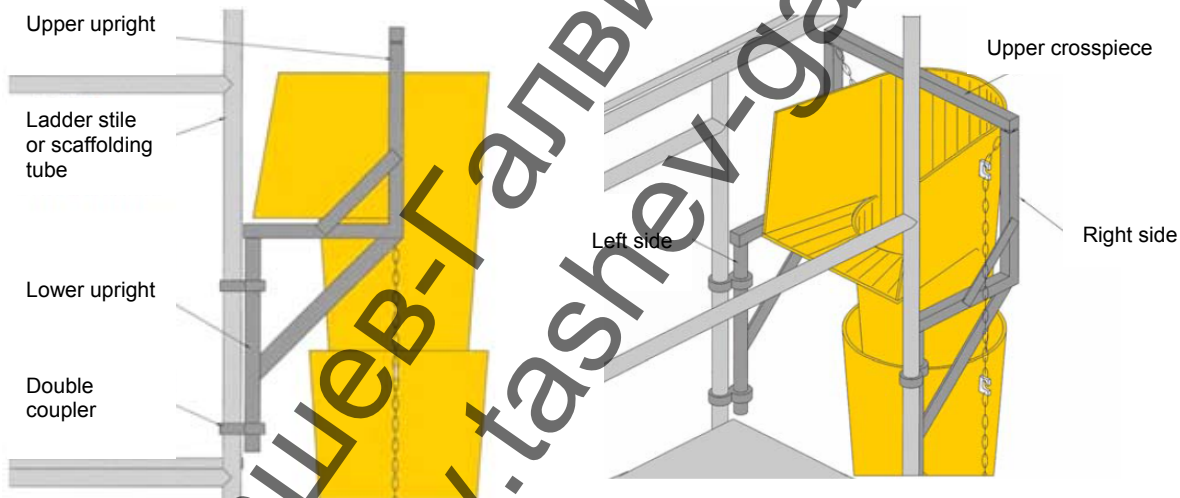

The chute sections can now be mounted to the scaffolding fixing frame.

Installing the platform fixing frame (see diagram):

It is intended for mounting to a concrete slab (on a balcony or terrace).

It can be mounted to concrete slabs of thicknesses varying between 200mm and 300mm (8" and 12") thanks to the two grip jacks.

The maximum number of chute sections that can be attached to a platform fixing frame depends on the height of the worksite:

- For heights up to 40m (131ft), a maximum of 16 chute sections can be attached to a platform fixing frame, representing a maximum distance of 13.60m (45ft) between two platform fixing frames. Moreover, an intermediate point of anchorage to the building is required between two fixing frames using a rope or a chain (not supplied).

- For heights ranging from 40m to 60m (130ft-196ft), a maximum of 12 chute sections can be attached to a platform fixing frame, representing a maximum distance of 10.20m (34ft) between two platform fixing frames.
- For heights above 60m (196ft), a maximum of 10 chute sections can be attached to a platform fixing frame, representing a maximum distance of 8.5m (28ft) between two platform fixing frames.
- Before installing the platform fixing frame, check the strength of the slab, balcony or terrace. Take into account the weight of the chute sections as well as the potential weight of the debris, which may obstruct the rubbish chute in case of improper use.
- Position the left side over the slab so that the slab is clamped between the lower supports and the plates of the grip jack, and that the frame's lower upright rests against the edge of the slab.
- Secure the installation by tightening the grip jack using the handle until the slab is flat against lower supports.
- Repeat the procedure on the right side.
- Use the upper crosspiece to adjust the distance between the left and right sides of the frame, and slot the crosspiece onto the fixing frame's upper uprights.
- Check that the installation is symmetric and level, then secure the installation by tightening the left and right grip jack handles so that the platform fixing frame is perfectly stable and secured to the building.

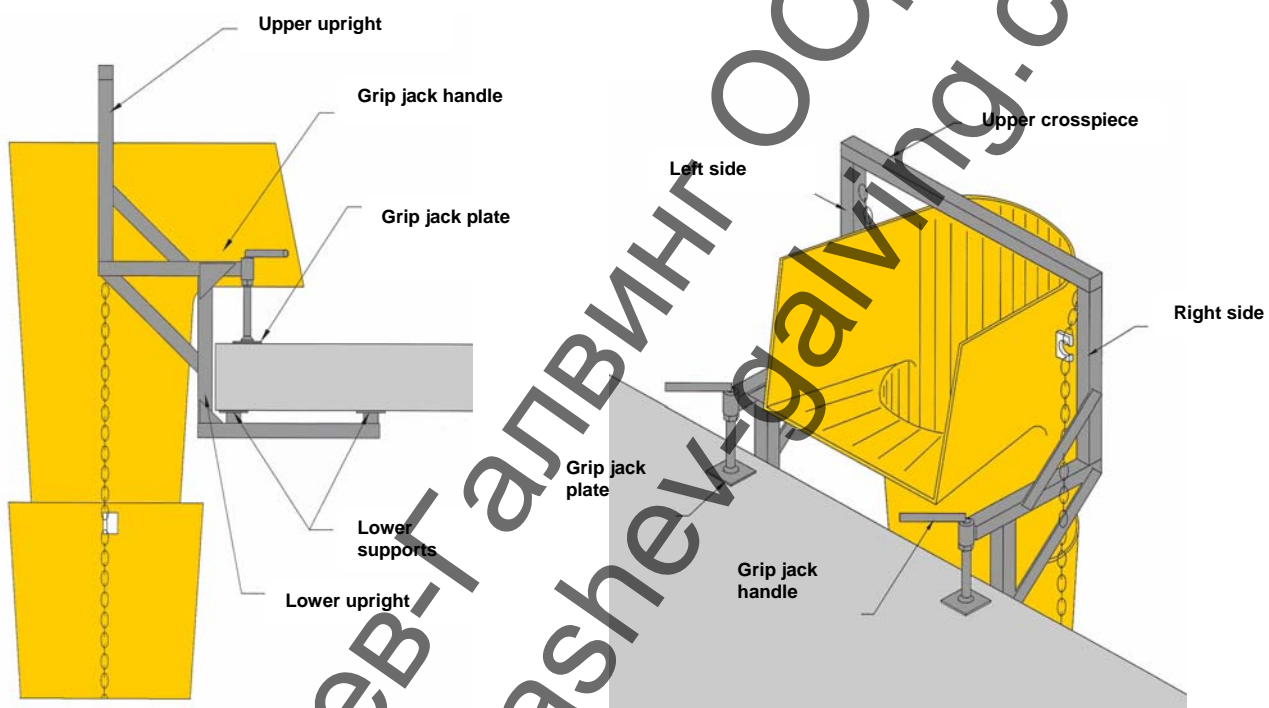

- The chute sections can now be mounted to the platform fixing frame.

Installing the chute sections:

- Cordon off the hazardous area when installing and using the rubbish chute. Ground-level workers must wear a safety helmet and keep back when the chute sections are being hoisted. Hoist-level workers using a winch or a rope to hoist the chute sections must wear a fall-arrest harness.
- Make sure that areas surrounding the installation and around the starting and finishing points of the rubbish chute aren't cluttered. When working in places over 2m (6ft) in height, guard rails must be used.
 - Use a rope or a winch to hoist the chute sections. As several people hoist the chute sections to the starting point, another person connects the chute sections together at the finishing point.
 - When the hopper chute reaches the starting point, attach the chains on the fixing frame to the anchorage plates on the hopper chute.

Attaching the chains

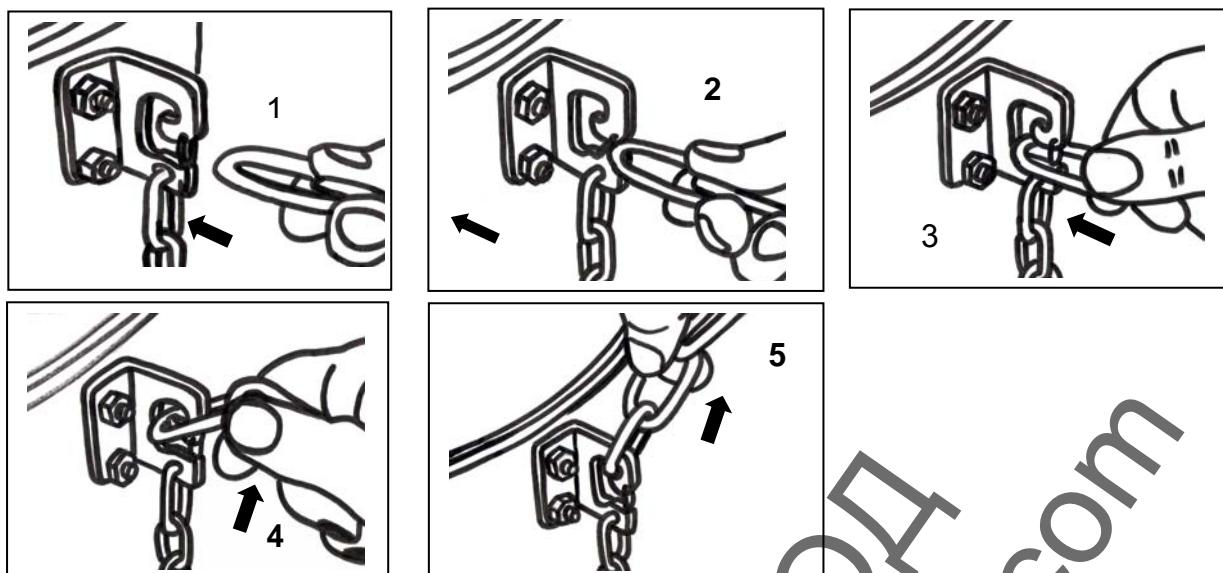

Disconnecting the chains

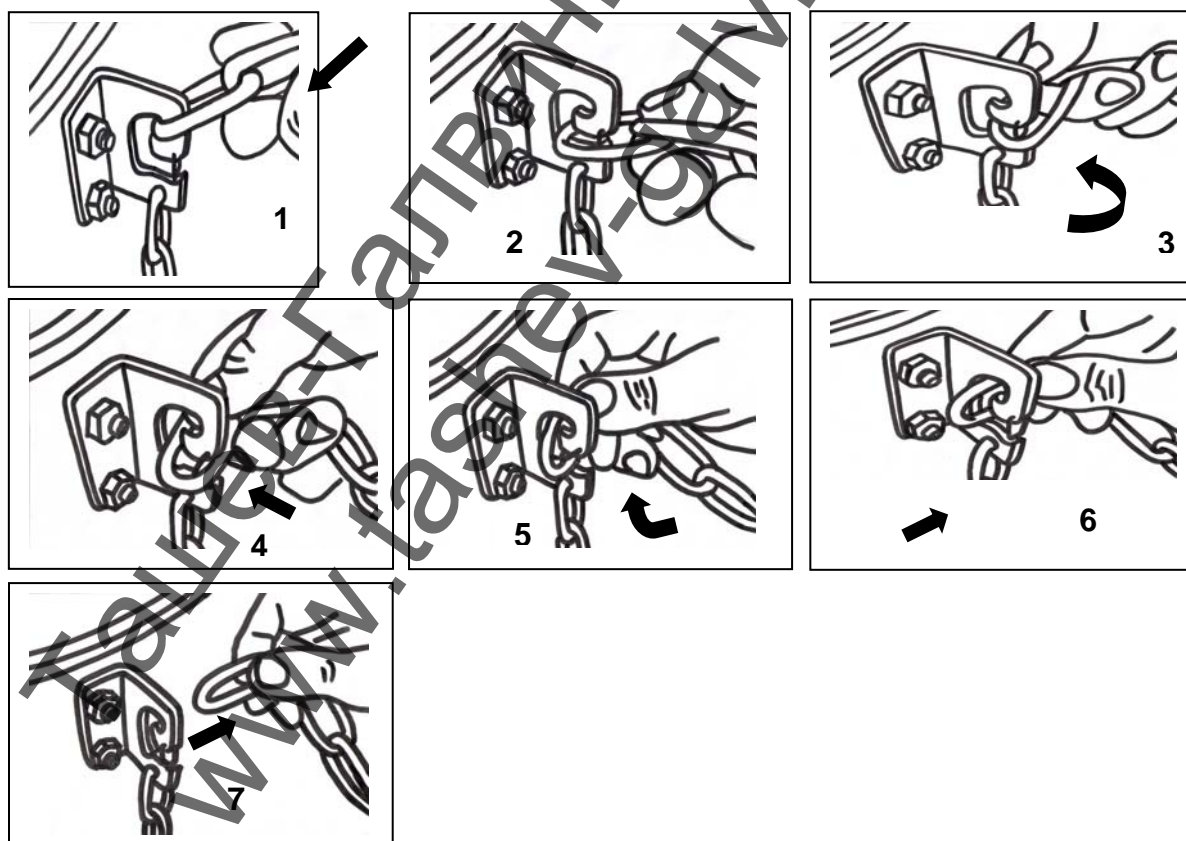

- Before using the installation, make sure there are no significant bends in the rubbish chute, which may obstruct the passage and lead to blockages. A rope may be used as a guide by passing it from one end of the rubbish chute to the other and taking up the slack.
- **Before using the installation, check that each of the chains is securely attached to the corresponding anchorage plate.**

RIGHT

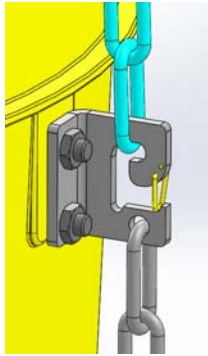

WRONG

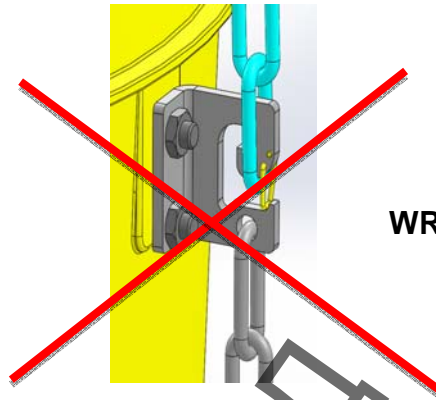

- Anchor the rubbish chute to the building using a rope or a chain every 10m (30ft).

The rubbish chute is now ready for use.

Ташев-Галвинг ООД
www.tashev-galving.com

Installing the chute sections using a hand winch (see diagram):

WARNING: the hand winch is not compatible with the window fixing frame!

- Cordon off the hazardous area when installing the rubbish chute. Ground-level workers must wear a safety helmet and keep back when the chute sections are being hoisted. Hoist-level workers using a winch to hoist the chute sections must wear a fall-arrest harness.
- Make sure that areas surrounding the installation and around the starting and finishing points of the rubbish chute aren't cluttered. When working in places over 2m (6ft) in height, guard rails must be used.
- Once the fixing frame is securely attached to the building, assemble the chute sections using a hand winch. The hand winch is only suitable for scaffolding fixing frames and platform fixing frames. It can hoist a maximum of 25 chute sections.
- Before installing the hand winch, check that the platform fixing frame or scaffolding fixing frame is correctly installed and perfectly secured to the building or scaffolding.
- Place the winch so that its left and right uprights rest on the side rails on either side of the fixing frame, and that the centre rail rests on the upper crosspiece of the fixing frame. Secure the winch to the fixing frame using the three (3) locking pins.
- The hand winch is now ready for use:
 - Use the crank handle on the winch to unwind the hoisting cable until the spreader bar arrives at the finishing point.
 - Connect the quick links on the spreader bar chains to the hopper chute chains. The quick links should be connected to the hopper chute chains within the top third of the chain.
 - Then, hoist the assembly using the crank handle on the hand winch at the starting point.
 - As the assembly is raised, a second person connects the chute sections by attaching the chains on the chute sections to the appropriate anchorage plates.
 - When the hopper chute arrives at the top, attach the chains of the platform fixing frame or the scaffolding fixing frame to the anchorage plates on the hopper chute.

Ташев-Галвини-Год
www.tashev-galvin.com

**Hand winch
Code 318104001**

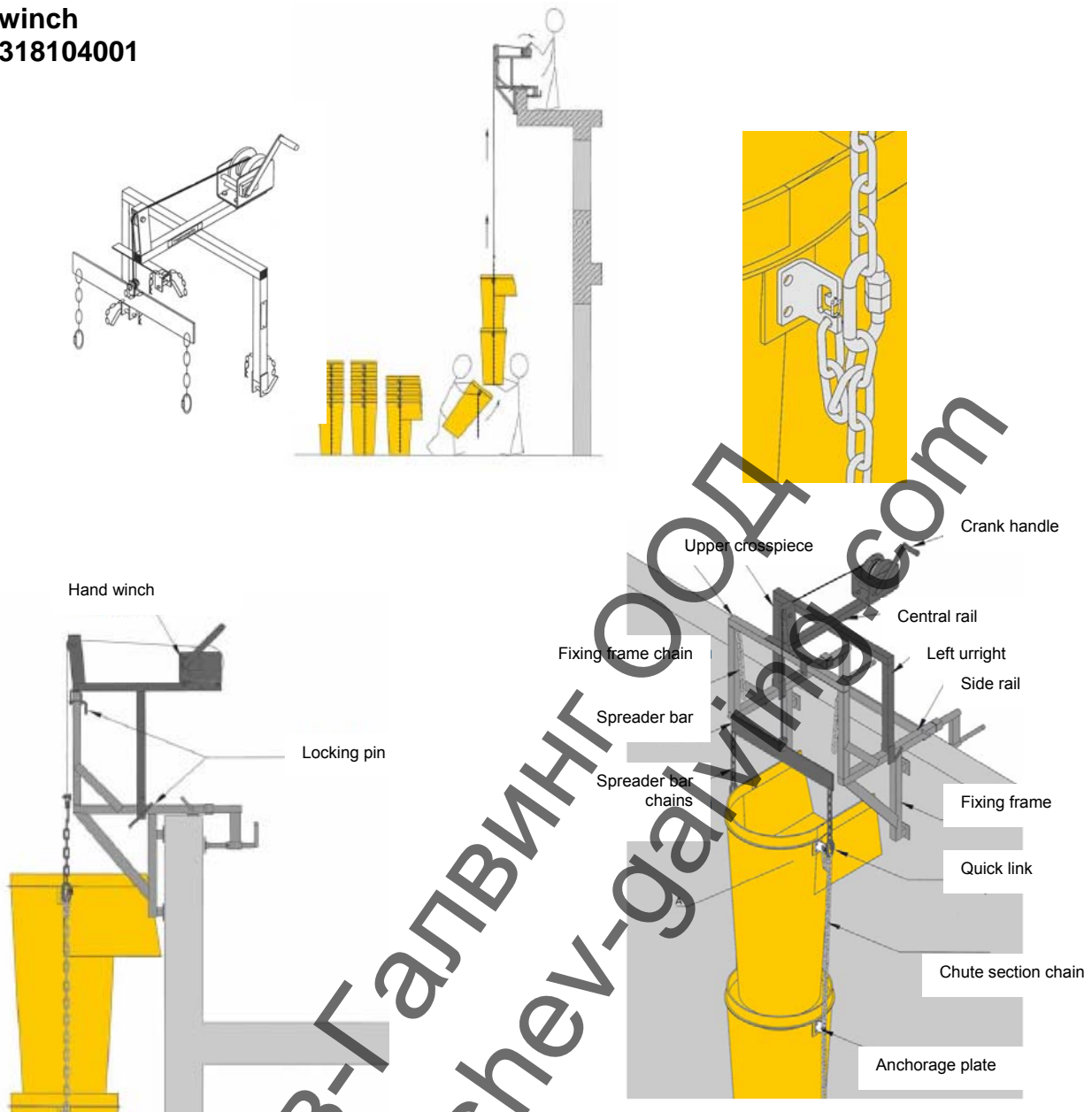

- When dismantling, use the crank handle on the hand winch to unwind the hoisting cable until the spreader bar chains with the quick links are loose enough to be disconnected from the hopper chute chains. Disconnect the spreader bar chains, then wind up the hoisting cable using the crank handle on the hand winch.
- Dismount the hand winch from the fixing frame, checking all fasteners, anchorage plates and chains.
- Before using the installation, make sure there are no significant bends in the rubbish chute, which may obstruct the passage and lead to blockages. A rope may be used as a guide by passing it from one end of the rubbish chute to the other and taking up the slack.
- **Before using the installation, check that each of the chains is securely attached to the corresponding anchorage plate.**
- Anchor the rubbish chute to the building using a rope or a chain every 10m (30ft).

The rubbish chute is now ready for use.

The chute sections may also be installed using an aerial lift basket or scaffolding!

Rubbish chute usage instructions:

- Only trained personnel are authorised to install, operate and dismantle the rubbish chute, the moderator and any accessories.
- Workers must wear PPE (safety gloves, safety helmet and safety goggles).
- The worksite must be strictly prohibited to the public.
- To ensure workers' safety, cordon off the hazardous area when installing and using the rubbish chute.
- Remember that it is dangerous and forbidden to bend over the opening of the rubbish chute or to stay close to the discharge end.
- Before installing or using the rubbish chute, individual or collective fall protection equipment is required at each level of the building.
- Leave a gap of at least 1m (3ft) under the discharge end of the rubbish chute to prevent debris from building up and causing blockages. Check the container regularly to make sure this 1m gap is respected.
- Check regularly to make sure the debris is being completely evacuated to avoid blockages, particularly at the moderators and at the discharge end.
- Also ensure that dust does not stick to the inside of the rubbish chute. This would increase the deadweight of the installation, impede the passage of the large debris and could cause blockages.
- In order to not put too much stress on the rubbish chute, avoid having any significant bends. To ensure the rubbish chute curves smoothly, guide down a rope to the other end, take up the slack and attach at the starting and finishing points.
- Anchor the rubbish chute to the building using a rope or a chain every 10m (30ft).
- Provide a tarpaulin for above the container to prevent dust from lifting and spreading.
- Only use the fixing frames for attaching the chute or hopper sections. They are not intended for any other use than those described in this technical note.

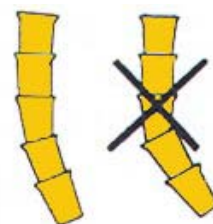

Mandatory safety rules:

- DO NOT install or use the rubbish chute, moderator or accessories in high winds or in stormy weather.
- DO NOT walk under the rubbish chute.
- DO NOT allow members of the public to approach, stay under or walk under the rubbish chute.
- DO NOT stay around the discharge end unless installing, checking or carrying out maintenance on the rubbish chute and moderator, making sure that nobody inserts any materials.
- DO NOT use the rubbish chute, moderator or anchorage accessories as a foothold.
- DO NOT use the rubbish chute or moderator for transporting people.
- DO NOT use the rubbish chute or moderator for any other use than their intended use.
- DO NOT introduce large objects or debris, which may obstruct the rubbish chute, particularly at the moderator section.
- DO NOT use a moderator if there is an intentional bend at the end of the rubbish chute.
- DO NOT send fresh concrete or liquid waste down the rubbish chute.
- DO NOT send objects or debris weighing more than 5kg (11lbs) down the rubbish chute. This may damage the chute sections or the moderators.
- DO NOT send long or bulky objects down the rubbish chute. This may obstruct or damage the chute sections or the moderators.

Maintenance:

- Check the rubbish chute's anchor points to the building or scaffolding daily.
- Check the chains and anchorage plates on the chute sections daily.
- Check that each chain is securely attached to the anchorage plate daily.
- Check that the moderators are securely attached to the chute sections daily.
- Clean the inside of the chute sections and moderators regularly to prevent blockages.
- Check that no debris is blocking the rubbish chute periodically.
- As soon as the chute sections, moderators or accessories show signs of wear, which may represent a risk to the user or to the environment, dismantle and replace with parts in good condition.

- **Workers must wear PPE (safety gloves, safety helmet and safety goggles) when carrying out maintenance.**

The service life of a chute section may be increased or reduced depending on the following:

- The type of debris (abrasive, sharp...).
- The size and weight of the debris (the effects that impacts and friction have are increased with heavy or large objects).
- The height (the effects that impacts and friction have are increased with the increasing speed of falling objects).
- The presence of significant bends at the discharge end (the chute sections at the bend will be more susceptible to impacts and friction).

When working on high buildings, the service life of the chute sections may be significantly increased, providing debris moderators are installed approximately every 10m (30ft), directly over the intermediary hopper sections. The moderator slows down the debris, significantly reducing the damage caused by impacts and friction, thus reducing wear and tear. The moderator also considerably reduces dust and noise. It is light, small and very easy to install on chute or hopper sections using the 3 bolts. It can be mounted to any chute or hopper section anywhere in the rubbish chute.

Remember that the moderator reduces the damage to the chute and hopper sections. Thus, the service life of a moderator will be significantly less than that of the chute and hopper sections. Therefore, the moderators will need to be replaced regularly.

Ташев-Галвинг ООУ
www.tashev-galving.com

Installing the moderator (see diagram):

- 1) Turn the chute or hopper section to be fitted with a moderator upside down.
Place the moderator on the chute or hopper section so that the 4 ribs on the inside of the moderator fit into place on the narrow end of the upside-down chute section.
- 2) Drill three $\varnothing 9\text{mm}$ ($3/8''$) holes into the chute section through the holes in the moderator, then remove the burr.
- 3) Fasten the moderator to the chute section using the three HXBT M8 x 25 bolts and $\varnothing 8\text{mm}$ ($5/16''$) washers. Insert the bolts so the bolt heads are on the inside of the chute section. The nut and washer should be fastened on the outside of the moderator.
- 4) Once the moderator has been securely assembled, the chute or hopper section is ready to be installed onto the rubbish chute.

Ташев-Галвинг ООД
www.tashev-galving.com

1 PLACE THE MODERATOR ON THE UPSIDE-DOWN CHUTE OR HOPPER SECTION

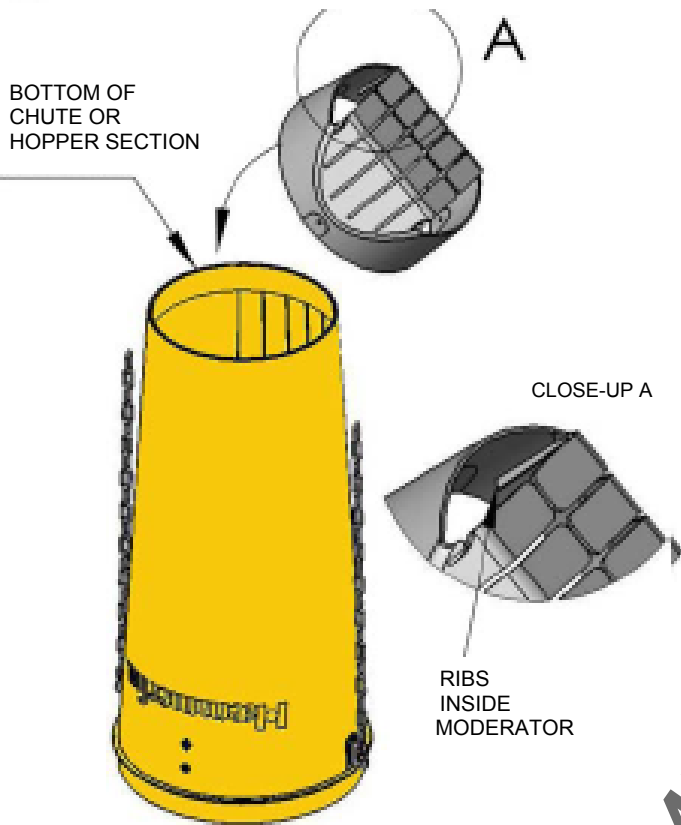

2 DRILL THREE Ø 9MM (3/8") HOLES INTO THE CHUTE SECTION THROUGH THE HOLES IN THE MODERATOR, THEN REMOVE THE BURR

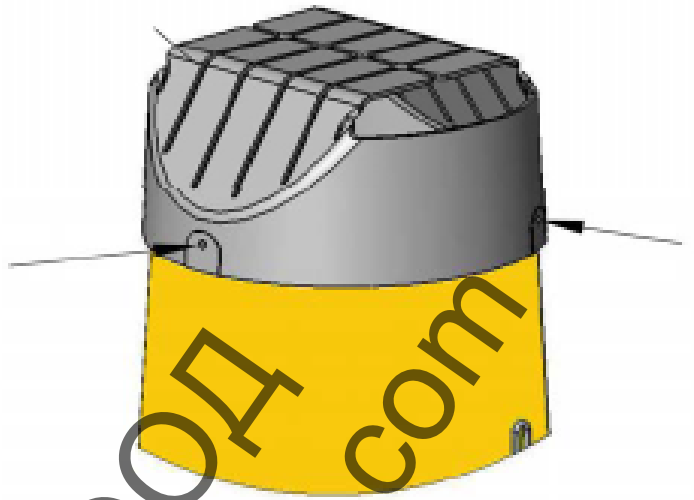

SECURELY ASSEMBLED SECTION CAN BE INSTALLED ONTO THE RUBBISH CHUTE

3 FASTEN THE MODERATOR TO THE CHUTE SECTION USING THE THREE HXBT M8 X 25 BOLTS

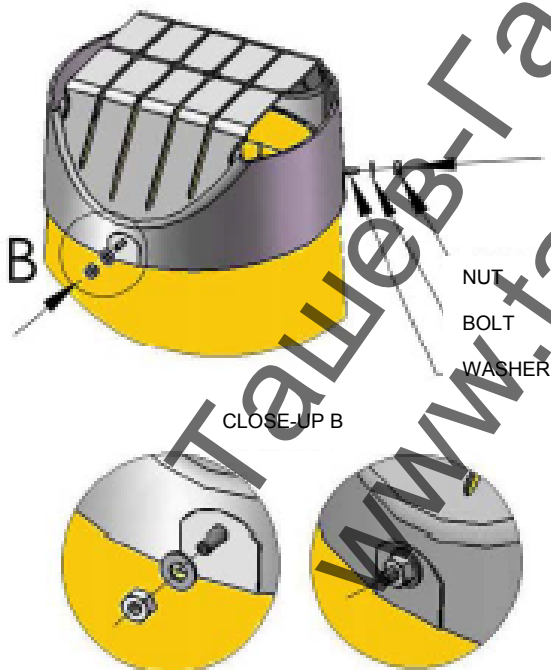

INSERT THE BOLTS SO THE BOLT HEADS ARE ON THE INSIDE OF THE CHUTE SECTION NUTS AND WASHERS SHOULD BE FASTENED ON THE OUTSIDE OF THE MODERATOR.

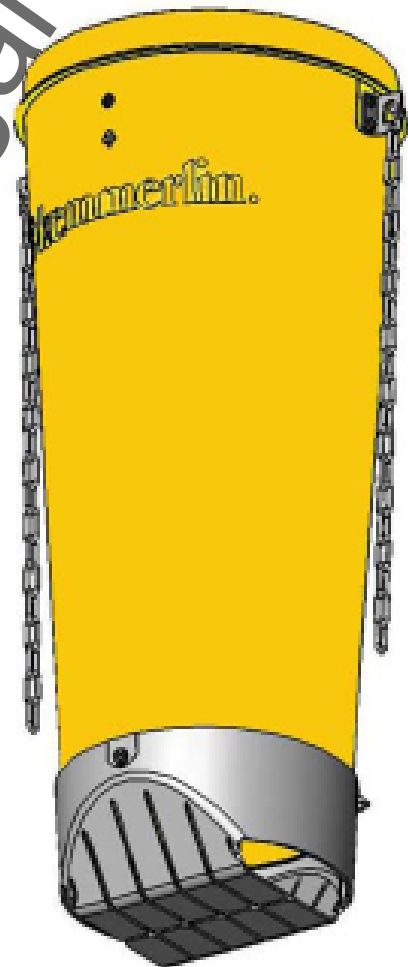

Ташев-Галвинг ООД
www.tashev-galving.com



hammerlin®



HAEMMERLIN - CDH GROUP
28 RUE DE STEINBOURG - BP 30045 - 67701 SAVERNE CEDEX - FRANCE
Tel. + 33 (0)3 88 01 85 00 - Fax + 33 (0)3 88 01 85 39
welcome@hammerlin.com - www.hammerlin.com